

25. INSTALLATION NOTES

Mounting:

The power terminals shall be located on top of the unit. An appropriate electrical and fire end-product enclosure should be considered in the end use application.

Do not install unit in airtight housings or cabinets. The site in which the unit is located must have sufficient ventilation acc. to EN50272-2.

Cooling: Convection cooled, no forced air cooling required. Do not obstruct air flow!

Installation clearances: 40mm on top, 20mm on the bottom, 5mm on the left and right side are recommended when loaded permanently with full power. In case the adjacent device is a heat source, 15mm clearance are recommended.

Risk of electrical shock, fire, personal injury or death!

Turn power off and disconnect battery fuse before working on the DC-UPS. Protect against inadvertent re-powering. Make sure the wiring is correct by following all local and national codes. Do not open, modify or repair the unit, except replacement of the battery. Use caution to prevent any foreign objects from entering into the housing. Do not use in wet locations or in areas where moisture or condensation can be expected.

Service parts:

The DC-UPS contains an integrated battery which must be changed on a periodic basis, see chapter 26 and. 28.1.

The tripping of an internal fuse is caused by an internal fault. If damage or malfunctioning should occur during operation, immediately turn power off and send unit to the factory for inspection! For Troubleshooting see 28.4.

Wiring and installation instructions:

- (1) It is recommended to install the DC-UPS in a place where the integrated battery will not be heated up by adjacent equipment. The unit is equipped with a fuseholder and a 30A battery fuse type ATO[®] 257 030 (Littelfuse). The battery fuse protects the wires between the battery and the DC-UPS. It also allows the disconnection of the battery from the DC-UPS which is recommended when working on the battery or DC-UPS. Disconnect battery fuse before connecting the battery.
- (2) Connect the power supply to the input terminals of the DC-UPS.
- (3) Connect the buffered load to the output terminals of the DC-UPS. The output is decoupled from the input allowing load circuits to be easily split into buffered and non buffered sections. Noncritical loads can be connected directly to the power supply and will not be buffered. The energy of the battery can then be used in the circuits which require buffering.
- (4) Plug-in the fuse when the wiring is finished.

Fig. 25-1 Typical wiring diagram

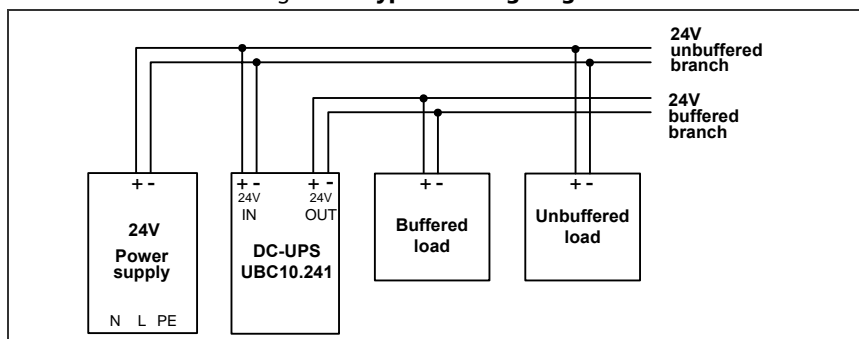

26. REPLACEMENT OF THE BATTERY

The integrated battery should be replaced on a periodic basis, see chapter 28.1 for additional information.

The replacement should be done by qualified personnel trained on battery handling.

Caution! The terminals on the battery are always alive, therefore do not place items or tools on the battery!

How to replace the battery:

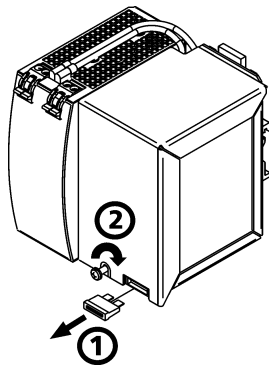

Step 1:
Remove the fuse before working on the unit.

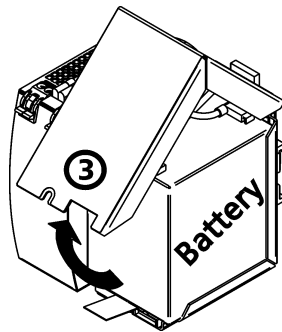

Step 2:
Loosen the captive cover screw.

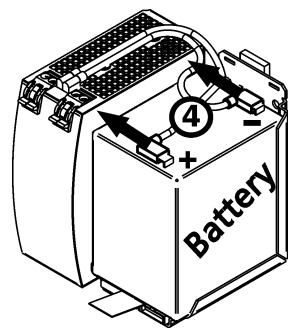

Step 3:
Remove the battery-cover.

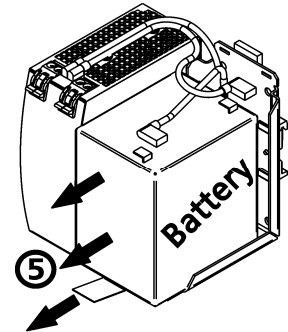

Step 4:
Disconnect the cables from the battery terminals.

Step 6: Install the new battery.

Step 7: Connect the red cable (+) to the red positive (+) terminal of the battery.

Step 8: Connect the black cable (-) to the black negative (-) terminal of the battery.

Step 9: Close the cover.

Step 10: Tighten the screw.

Step 11: Plug-in the fuse.

Step 5:
Remove the battery by pulling on the strap.

Disposal of batteries

Batteries marked with the recycling symbol should be recycled through a competent agency.



Replacement battery

See chapter 27 for information on the UZB12.051 or you can use a battery which meets the following requirements:

Battery type	nom.	12V, 4 to 6Ah	VRLA lead-acid maintenance free battery
Design life	min.	3 to 5 years	According to EUROBAT guideline
Dimensions	nom.	70x106x90mm	WxHxD *)
Pole connection		6.35mm/ 0.25Inch	Blade type; Fast-on
Approvals		UL, VdS	For applications which require UL or VdS
Allowed discharge current	min.	29A	Continuous

*) Max. case height of 102mm